

SNC-6-XX-300

Pump Dimensions

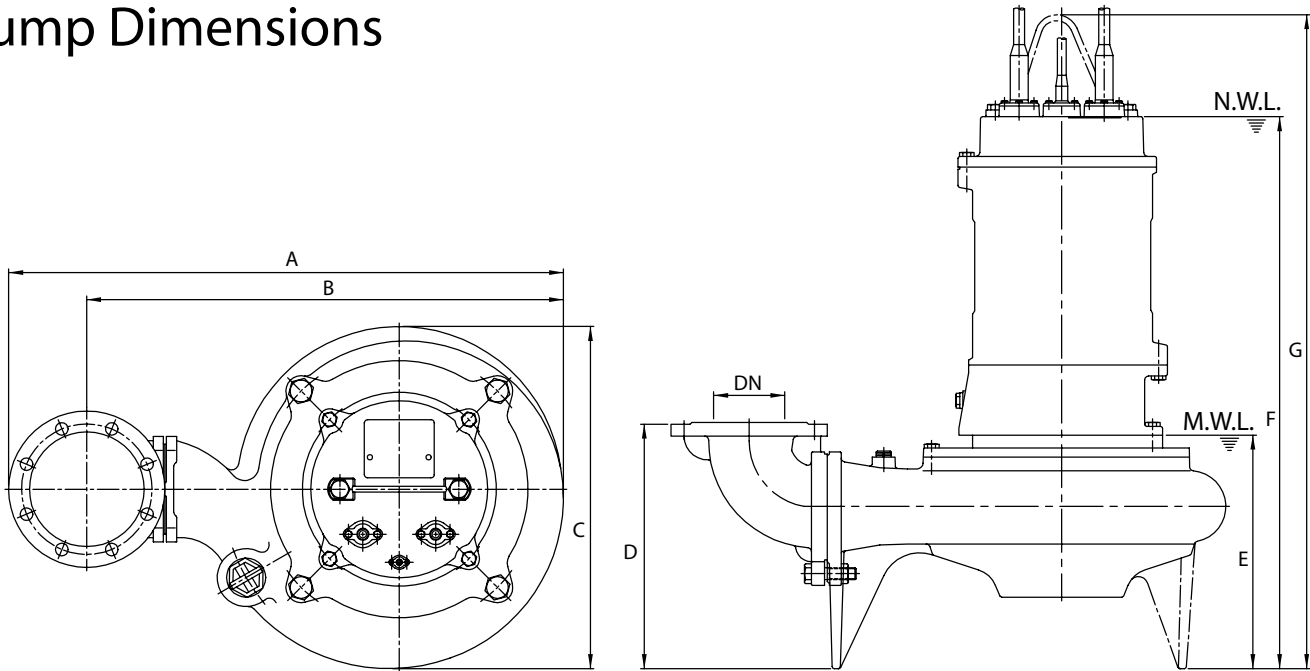

Type	DN	A	B	C	D	E	F	G
SNC-6-XX-300	6.00	33.50	28.00	19.63	15.63	13.00	34.25	40.18

N.W.L.: Normal water level
M.W.L.: Minimum water level

Easy Lift GRS - Guide Rail System Dimensions

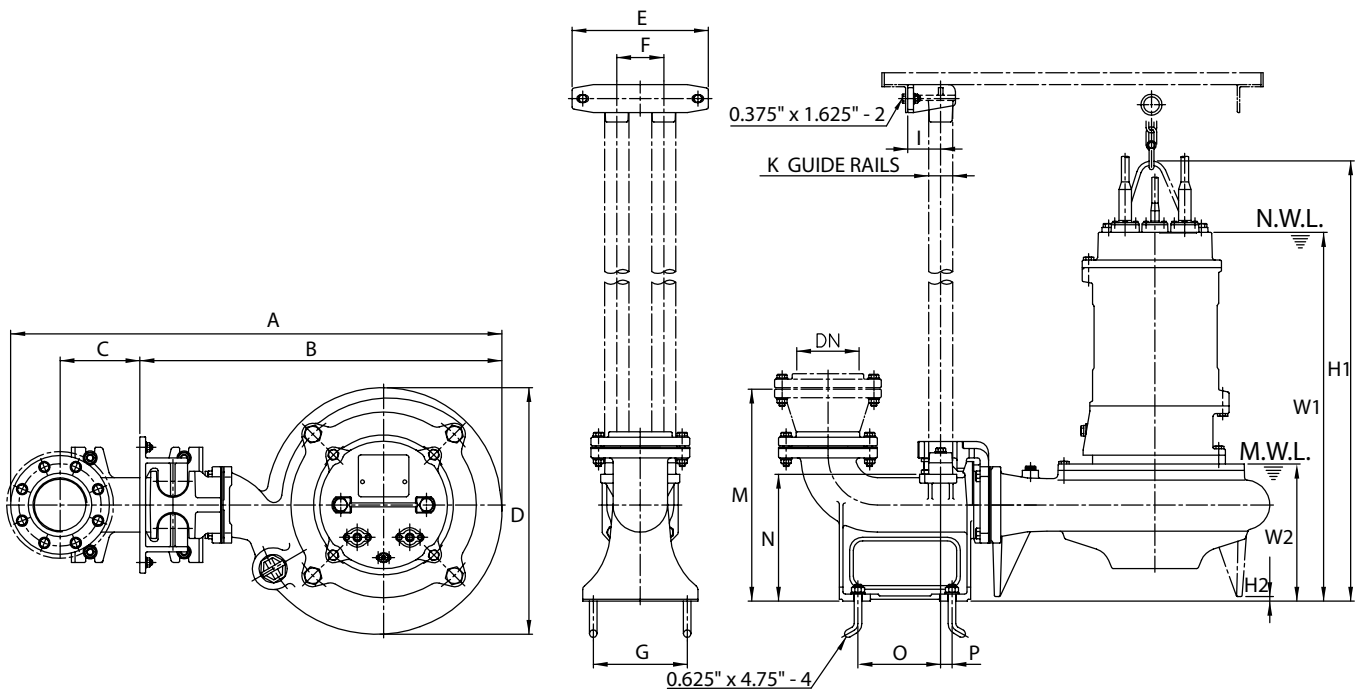

TYPE	DN	A	B	C	D	E	F	G	I	K	M	N	O	P	W1	W2	H1	H2
SNC-6-XX-300	6	38.00	30.13	6.63	19.63	11.38	3.88	7.88	2.75	2.00	12.75	10.63	6.88	1.63	34.63	13.00	45.63	0.38

All dimensions are in inches unless otherwise noted.